

WBT-0210 Ag

E

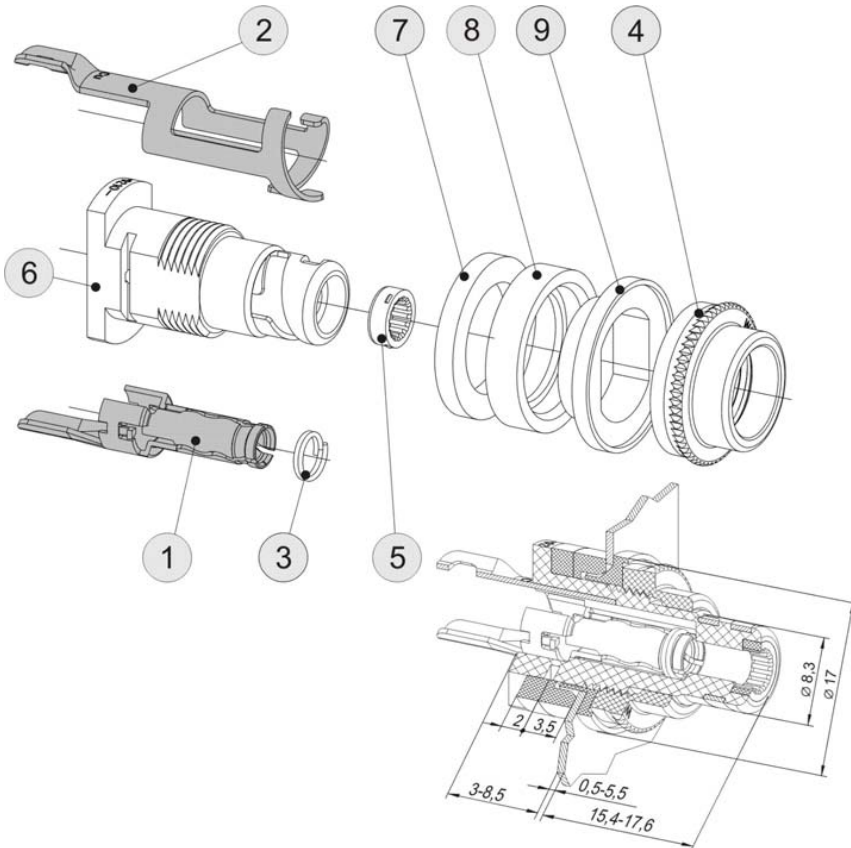

**Component list**

1	Signal Conductor 'Plus', fine silver	1
2	Signal conductor 'Minus', fine silver	1
3	Contact spring bronze	1
4	Counter nut, PA 6.6 fibre-glass reinforced	1
5	Marking ring Badamid B70 GF10 <sup>1)</sup>	1
6	Base element PA 6.6 fibre-glass reinforced	1
7	Distance ring PA 6.6 fibre-glass reinforced	1
8	Distance ring PA 6.6 fibre-glass reinforced	1
9	Double Step washer PA 6.6 fibre-glass reinforced	1

Extent of delivery 1 – 9 mounted

Revision date 14.12.2006

<sup>1)</sup> Badamid is a registered trade mark of Bada AG • WBT und nextgen are registered trade marks of WBT GmbH

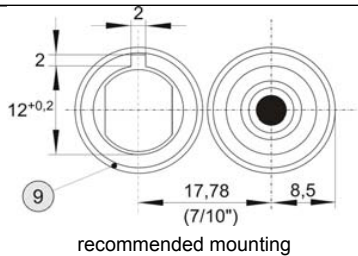

WBT-0210 Ag  
Characteristic impedance 75Ω  
RoHS compliant

**WBT – 0210 Ag Coaxial Socket nextgen™**

(Internat. Pat. EP 0 460 145 B1)

Coaxial socket for cabinet mounting, *soldering version*

**1. Mechanics**

- One-piece low tolerance contact elements (Tol. < ± 0.02 mm)
- Outer conductor with low capacitance patented contact form
- Inner socket with well defined contact surface, WBT active spring mechanism with enclosing beryllium spring; large spring travel for constant contact pressure even with imprecise counter pieces

**2. Materials**

- Signal conductor (1) und (2) fine silver
- Base element (6) high strength fibre-glass reinforced Polyamide
- Mounted parts (7), (8) und (9) fibre-glass reinforced Polyamide 6.6
- Marking ring Badamid B70 GF10
- Counter nut fibre-glass reinforced Polyamide 6.6

**3. Surfaces**

- Signal conductor Ag, passivated

**4. Operating Characteristics (reliable observed after more than 10<sup>3</sup> connections/disconnections)**

- Permanent current I<sub>D</sub> > 20 A
- Transition resistance R<sub>D</sub> < 0.1 mOhm (loop measured with WBT -0110)
- Contact resistance R<sub>Bi</sub>, R<sub>Bo</sub> < 0.1 mOhm (patch resistance, inner / outer)
- Self capacitance C ≈ 2.5 pF
- Insulation resistance R<sub>is</sub>, R<sub>isG</sub> > 10<sup>10</sup>ohms (conductor/conductor, conductor/chassis)
- Characteristic impedance Z = 75 Ohms

**5. Terminals**

- solder, for cables up to 1.5 mm<sup>2</sup>

**6. Mounting**

- problem-free by hand using the knurled nut
- recommended distance between socket centres: 17,78 mm = 7/10 inch (standard)